

# AVERY DENNISON MARKETING SPECIFICATION

## HISTORY

REV.	DATE	DESCRIPTION
A	1/19/07	RELEASE TO PRODUCTION
B	4/6/07	NEW PRODUCTION TOOL
C	6/16/08	MODIFY STANDOFF GEOMETRY
D	08.03.18	UPDATES TO NEW FORMAT; ADDED -0 TO PART NUMBER; ADDED SPECIAL CHARACTERISTIC NOTE; ALL NUMBERS READJUSTED TO AVERY DRAWING STD.

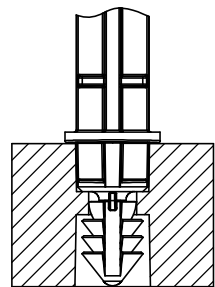

**ASSEMBLED VIEW**

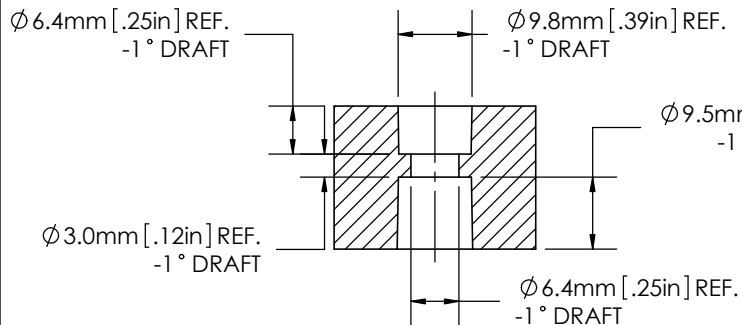
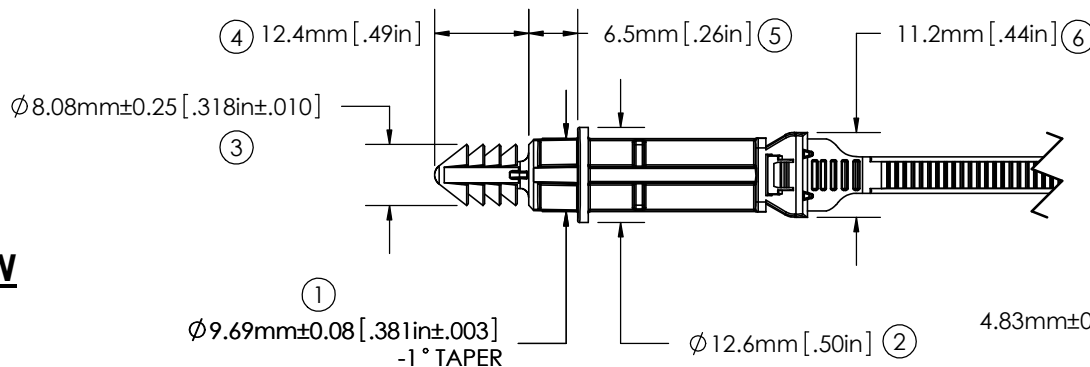

**MOUNTING HOLE DETAIL**

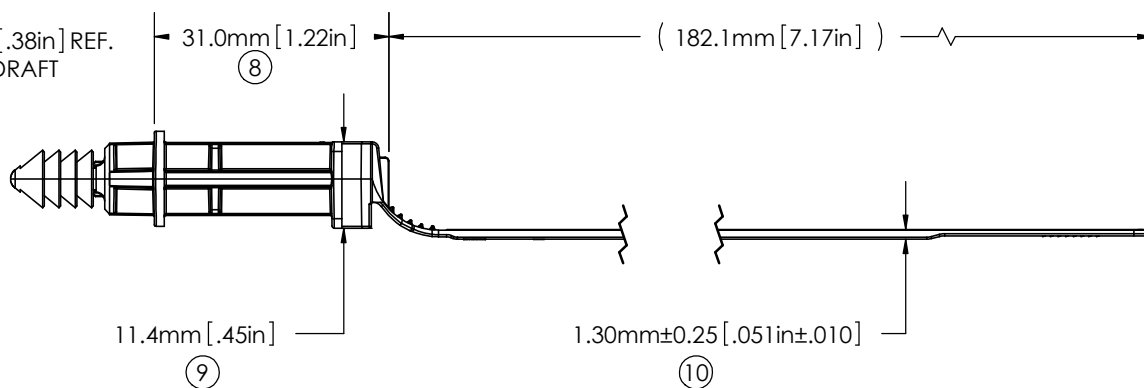

⑨	△	FLAMMABILITY:	HB RATED PER FMVSS302
⑩	△	TENSILE STRENGTH:	222N / 50 LBF MIN.
		MOUNTING:	SEE MOUNTING HOLE DETAIL AND ASSEMBLED VIEW
		OPERATING TEMP RANGE:	-40°F (-40°C) TO 220°F (105°C)
		WEIGHT:	3.2g
		BUNDLE DIAMETER:	Ø 1.6mm [.06in] TO Ø44.5mm [1.75in]
		TOOL:	12001 - HAND TOOL 12500 - PNEUMATIC TOOL
		TOOL TENSION SETTING:	6 - 8
		PACKAGING:	500/BAG, 10 BAGS/MASTER

**NOTES:**

1. △ = INDICATES SPECIAL CHARACTERISTIC

<b>APPROVALS:</b>	ENG. APPR. <i>Daniel Gilbertson</i>	08.03.18
	Q.A. APPR. <i>Rick Estano</i>	08.03.18

GENERAL TOLERANCE  
UNLESS SPECIFIED ± 0.5mm [.02in]

.X ± —      .XXX ± —  
.XX ± —      ANGULAR: ± 3°

MATERIAL **NYLON 6/6,  
IMPACT MODIFIED, HEAT STAB.**

COLOR  
**BLACK**



FASTENER DIVISION  
FITCHBURG, MA 01420 U.S.A.  
TEL. 1-800-225-5913  
FAX. 978-353-8157

DESCRIPTION  
**FIR TREE STANDOFF TIE**

PART NO. **20106-0**      REV. **D**